



M7 TECHNOLOGY

SOLUTIONS, INC.

“Innovative Solutions, Excellence in Service”



About M7 Technology Solutions, Inc.

Is a company that focuses on the growth of its employees and its customers. We strive to provide opportunities to grow and focus on our action within the context of seven Filipino values: honorable, humane, faithful, trustworthy, steadfast, resourceful, and skillful.

Founded on July 12, 2012, we specialize in sourcing and delivering products that are tailored to meet the unique needs of our clients. With a strong focus on the semiconductor and electronics industries, we ensure that our products and services are customized to fit exact specifications, always aiming for customer satisfaction with flexible, efficient solutions.

In addition to sourcing, we provide technical, application and service support in industries like semiconductors and electronics. Our dedicated team works closely with customers to deliver optimal results.

We prioritize building lasting relationships with our customers, making us a trusted partner in helping businesses achieve their goals.

Our Organizational Chart

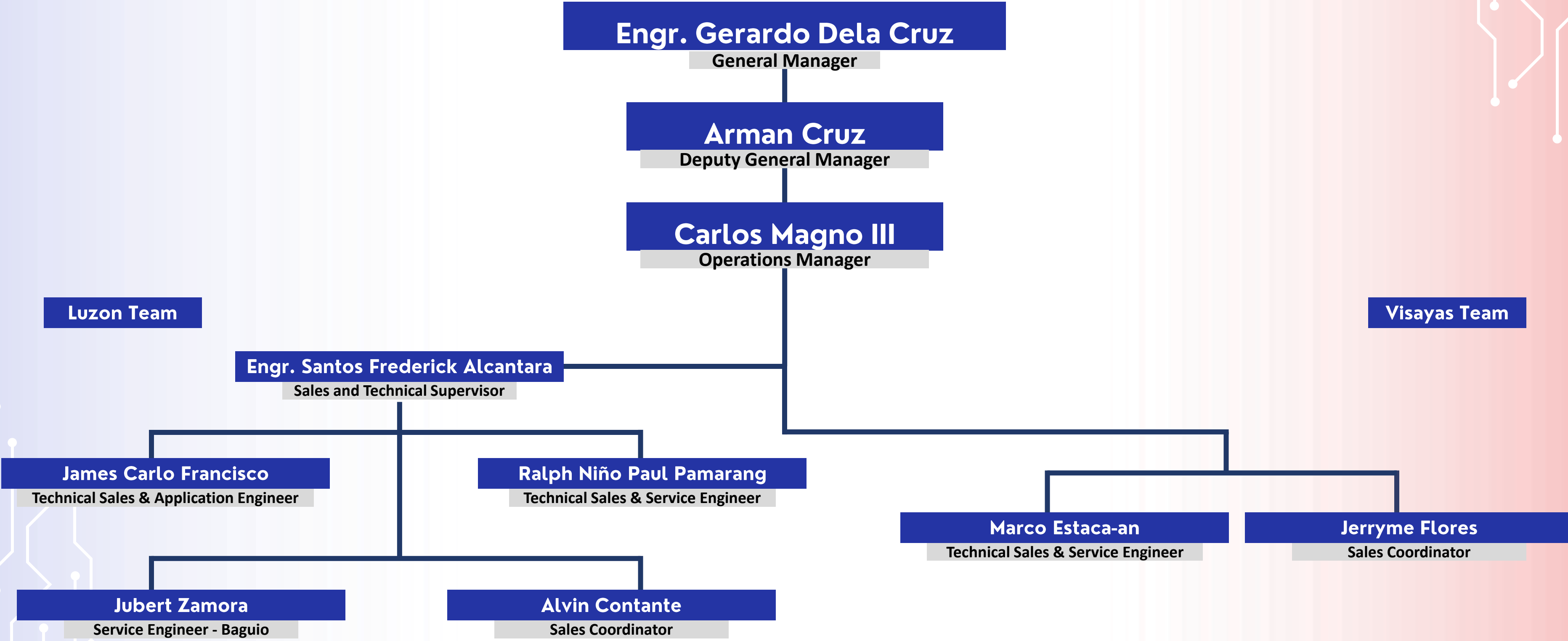

Luzon Team

Visayas Team

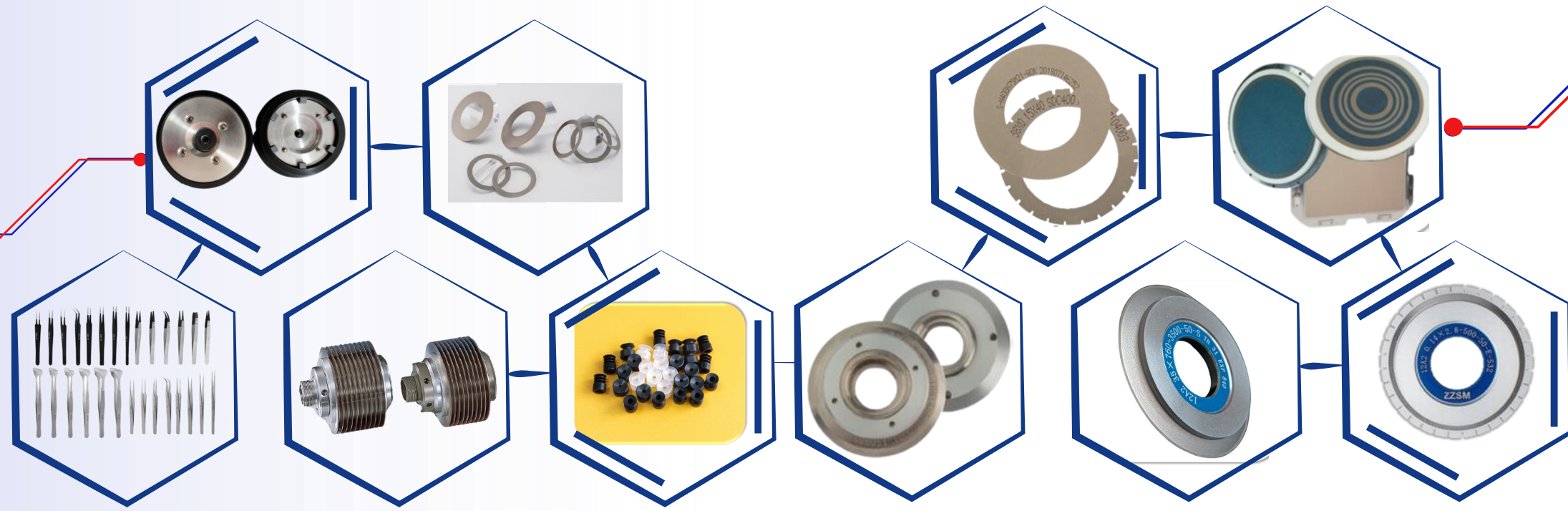

OUR PRODUCTS



READ DICING BLADES

ELF ELECTROFORMING BOND

High-speed cutting with minimal chipping for SiC wafer-based power devices, which typically feature metal plating on the entire backside









  READ ELF 56D x 0.027T x 40H (Hubless Type)		Blade	OTHER COMPANY
56D x 0.021T x 40H (Hub Type)		56D x 0.021T x 40H (Hub Type)	56D x 0.021T x 40H (Hub Type)
15 mm/sec	Speed	10 mm/sec	
✓	Straightness	✓	
✓	NO Chipping	✗	
	Chipping Size		

Remark : 1-pass through cut



SSB/SSH (Metal-Resin-Vitrified) Bond

Exceptional self-refreshing of diamond grits through the SSB/SSH original bond and superior blade shape control via 3-layer structure

  READ SSB / SSH		Blade	OTHER COMPANY
80 mm/sec	Speed	50 mm/sec	
10 km	Long Life	5 km	
	Full Cut		
	Half Cut (for QFN wettable flank)		
	Grooving test on in-plated copper sheet		

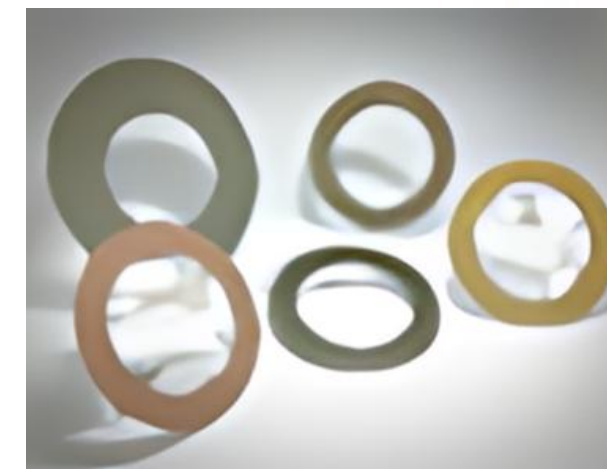

READ DICING BLADES

MULTI-GANG DICING BLADE

Assembled 2 to 80 blades with micron-level precision. Accuracy ensured through comprehensive test cut results prior to shipping. Able to match wheel specifications to suit the processing purpose

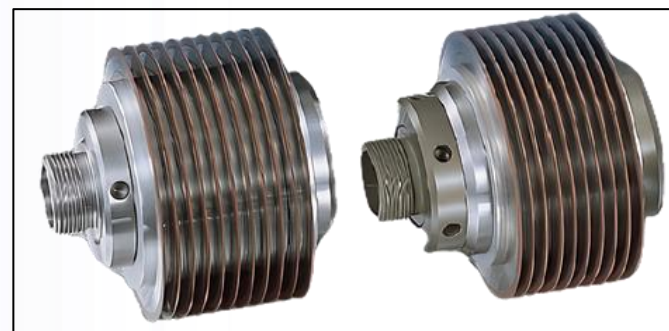
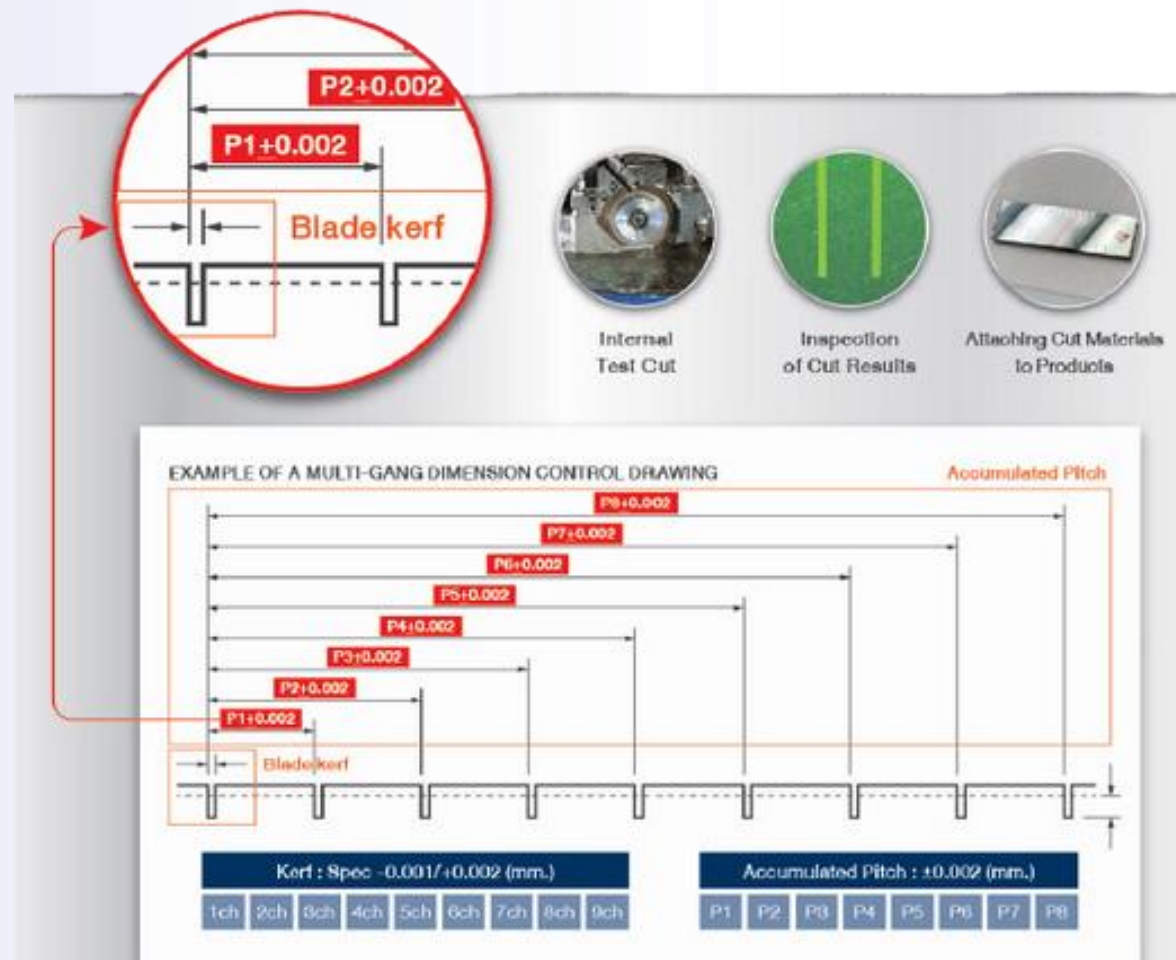

THREE-LAYERED-BLADE

Diamond blade composed from different 3 layers specification. High quality is needed. But higher speed processing is necessary, too. Rough size diamond is in center layer for high grinding ability. Fine size diamond is in each side layers for maintain the good quality.

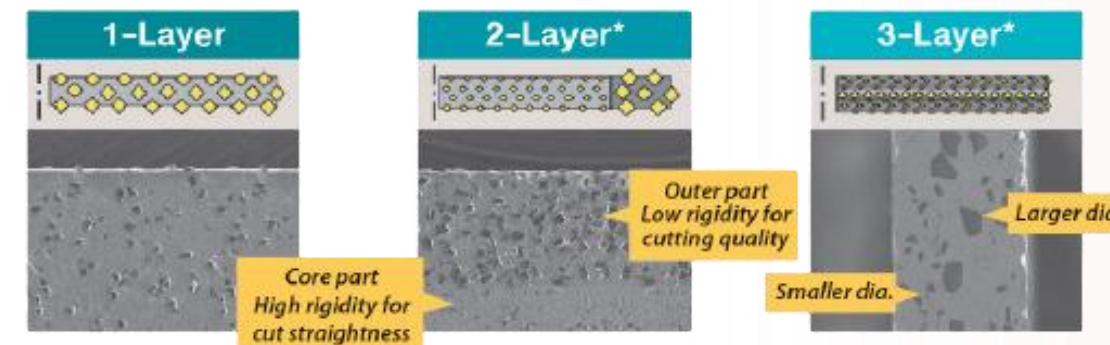

3 layers blade

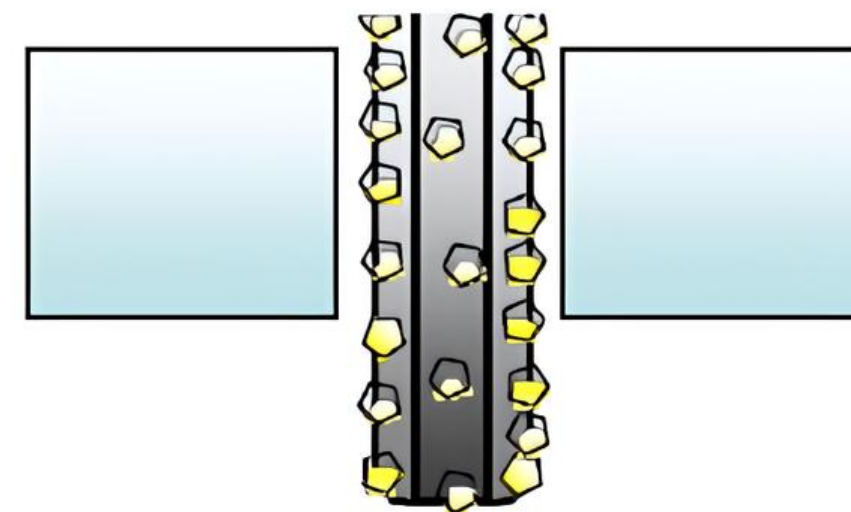

DICING BLADES

NICKEL BOND ELECTROFORMED

Using electro plated nickel bond, ultra thin hub blades can provide stable dicing performance of narrow street wafer. With full thickness serial can meet various kerf requirement, with minimum blade thickness from 10-15 um to meet narrowest dicing street.

APPLICATION

Silicon wafer, compound semiconductor wafers [Si, SiC, GaAs, GaP, oxide wafer(LiTaO3)] and others.

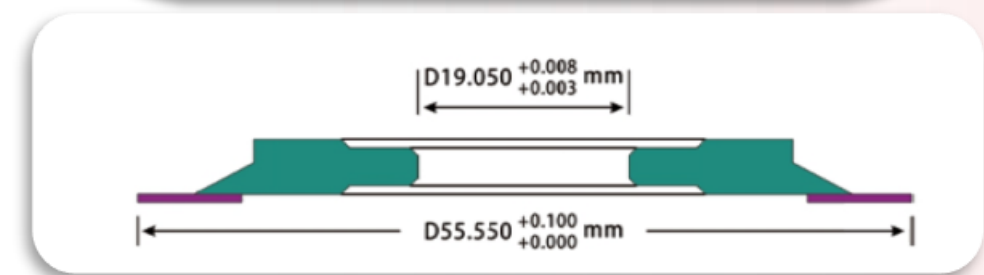

S P E C I F I C A T I O N S

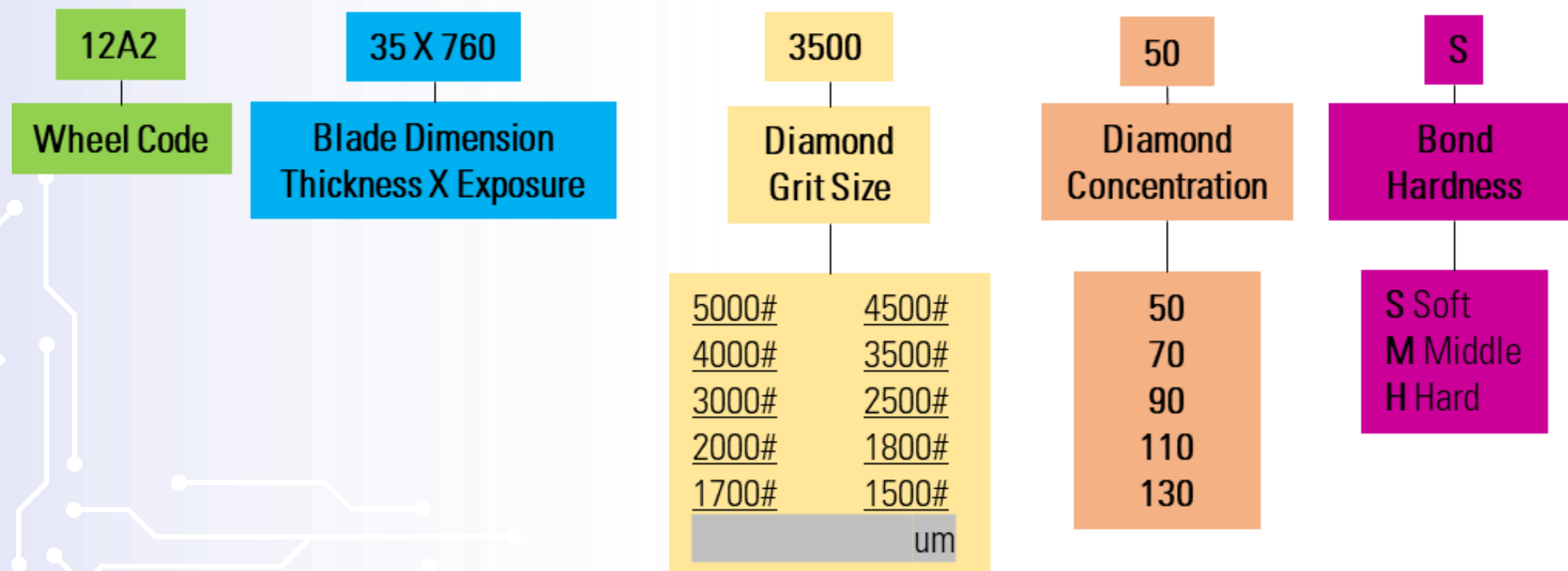

DICING BLADES

NICKEL BASED for PACKAGE DICING

Sharpness cutting and elastic bond can improve the surface quality. High precision, less dress or no need to dress. Widely used, variety specifications.

APPLICATION

BGA, LGA, LED, QFN Optical glass, Optical communication fibers, diodes , blue glass, crystal and gem and so on.

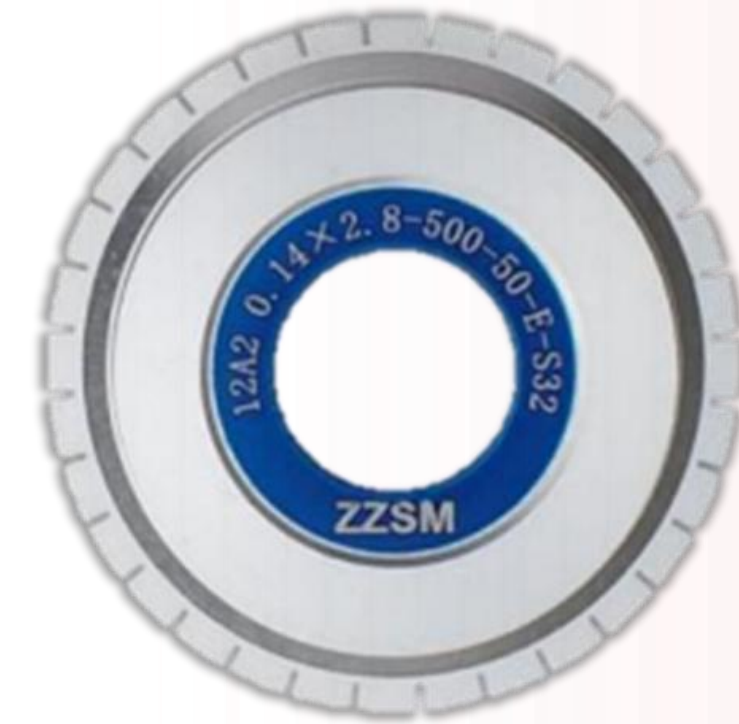

S P E C I F I C A T I O N S

12A2 - 50 x 0.22 C x 4.2 - 400 - 50 - E1 - S48

O.D.	Thickness		Tolerance	Exposure		Grit Size	Concentration	Bond	Slits	
50 ~ 58 (mm)	0.06	0.20	A ± 0.005	2.0	3.4	1200	30	E1	S8	8
	0.08	0.22	B ± 0.010	2.2	3.6	1000	50	E2	S16	16
	0.10	0.24	C ± 0.015	2.4	3.8	800	70	E3 (hard)	S32	32
	0.12	0.26	(mm)	2.6	4.0	600	90		S48	48
	0.14	0.28		2.8	4.2	500	110		S64	64
	0.16	0.30		3.0	4.4	400	130			
	0.18	0.32		3.2	4.6	340	150			
	(mm)				(mm)					

Innovative Solutions, Excellence in Service

DICING BLADES

NICKEL BASED for PACKAGE SINGULATION HUBLESS

Electroformed nickel-based binder is used with coarse-grained diamond to achieve ultra-long life cutting. A combination of nickel bond and larger size diamond grits provides long blade life performance.

APPLICATION

Various semiconductor package substrates such as alumina ceramics, EMC (thermosetting resin), PCB, etc.

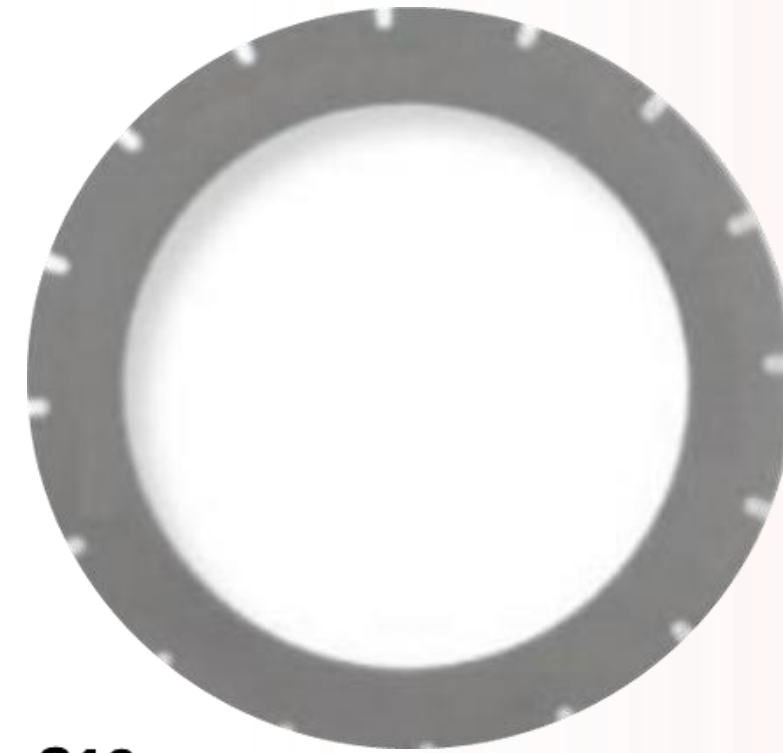

S P E C I F I C A T I O N S

1A8 58 X 0.22 C X 40 - 600 - 90 - E1 - S16

O.D.	Thickness		Tolerance	I.D.	Grit Size	Concentration	Bond	Slits
50 ~ 58 (mm)	0.06	0.20	A ± 0.005	40	1000	30	E1	S8 8
	0.08	0.22	B ± 0.010	(mm)	800	50	E2	S16 16
	0.10	0.24	C ± 0.015		600	70	E3 (hard)	S32 32
	0.12	0.26	(mm)	500	90		S48 48	
	0.14	0.28		400	110		S64 64	
	0.16	0.30		340	130			
	0.18	0.32		320	150			
	(mm)							

Innovative Solutions, Excellence in Service

DICING BLADES

RESIN BOND

Resin bond dicing blades without steel core is mainly used for precision cutting and slotting for semiconductor, optical glass, quartz glass, ceramics and so on.

APPLICATION

QFN, LGA, LED, BGA, DFN, diodes, blue glass, crystal, magnetic materials.



SPECIFICATIONS

T \ D	50-60	60-76.2	77-101.6	102-125	125-156	Thick Tolerance
0.06						±0.005
0.1						
0.2						
0.3						
0.4						
0.5						±0.008
1.0						
1.5						
2.0						
H	25.4, 31.75, 40, 52, 69.875, 88.9, 114.3					

- T : Thickness
- D : Outer Diameter
- H : Inner Diameter

Innovative Solutions, Excellence in Service

DICING BLADES

METAL BOND

Metal bond high precision dicing blades without steel plate are made of identical material, with thin thickness and high precision, they are mainly used for grooving and cutting with high accuracy and slight cutting depth.

APPLICATION

BGA, LGA, LED diode, optical glass, tool steel and stainless steel.



SPECIFICATIONS

	10-58	60-76.2	78-101.6	101.6-127	130-200	Thick Tolerance
0.07						±0.002
0.1						
0.2						
0.3						±0.005
0.4						
0.5						
1.0						
1.5						
2.0						
H	6, 8, 9, 10, 12.7, 25.4, 31.75, 40, 41.275, 50.8, 76.2 69.875, 88.9, 114.3					

- T : Thickness
- D : Outer Diameter
- H : Inner Diameter

Innovative Solutions, Excellence in Service

DRESSER BOARDS

The dressing plate, which is for cutting blades used in semiconductor package, mainly consists of ceramic or resin as bond and silicon carbide or corundum as abrasive. It is for truing and dressing the blades, which is used in cutting semiconductor package and glass.



CARBON BRUSH

The carbon brush makes sure the commutation process remains free from sparks and helps conduct electric current between the moving parts of the motor. The brush is also responsible for changing the course of current in the conductors during the rotation process.



BBD FIBER PRISM

Fiber type : Flexible
Sensing Distance(BR2/L999): 9mm
Operate temperature: - 40 °C ~ + 70 °C
Minimum bending radius: R2
Fiber Diameter: OD = \varnothing 2.2 : \varnothing 1.0



NCS FIBER PRISM

Fiber type : Flexible
Sensing Distance(BR2/L999): 9mm
Operate temperature: - 55 °C ~ + 70 °C
Minimum bending radius: R2
Fiber Diameter: OD = \varnothing 2.2 : \varnothing 1.0



VACUUM PADS

Vacuum pads engage an object and attached to it with an applied, sealed vacuum. The pads can be actuated to lift, move, or position the work piece in assembly or inspection applications.

There are types of vacuum pads:

- Flat type
- Bellows type
- Thin Flat type



FLANGES

The flange is a special tool for clamping all kinds of ultra-thin blades on the precision dicing machine. Compatible with DISCO, ADT and TSK Dicing Machine.

It is divided into two categories:

- Flange: Clamping blades with hub
- Wheel Mount: Clamping hubless blades



S P E C I F I C A T I O N S

Face Runout	Radial Runout	Vibration Intensity
≤2μm	≤3μm	≤0.4mm/s

UV TAPES



UV Tape is a special tape, which has excellent adhesiveness under normal conditions. But its adhesiveness decreases rapidly after exposure of UV light. UV tape usually as carrier tape and protective substrate during the dicing and grinding process.

S P E C I F I C A T I O N S

Base film	Thickness(um)	Adhesive	Adhesive thickness (um)	Adhesion (before UV) g/25 mm	Adhesion (after UV) g/25mm
P O	80, 100, 140, 150	UV	5~30	500~3000	<20
PET	50, 100, 188	UV	5~30	500~3000	<20

CHUCK TABLES

Fine-pore ceramic chuck table has the characteristics of high flatness and parallelism, compact and uniform structure with high strength, good permeability, uniform adsorption affinity and dressing easily.

MAIN FEATURES:

High Flatness and Parallelism

Compact and uniform microstructure with high strength. Good permeability and uniform absorption affinity

Compatible with the ff Grinding and Dicing Machine:

GRINDING:

DISCO – DAG810/83H/6/82IF/ 800 SERIES, 8000 SERIES

ACCRETECH – PG200/PG300

OKAMOTO – VG401/VG502

STRASBAUGH – 7AF

ADVANCED MACHINE TECHNOLOGY – VRG250S

DICING:

DISCO – DAD/DFD 300 SERIES/500 SERIES/600 SERIES/6000 SERIES/3000 SERIES

ADT – 7100/7200/7500/7900 SERIES

ACCRETECH – A-WD SERIES



Size	Parallelism
4 inch	3μm
6 inch	3μm
8 inch	5μm
12 inch	5μm

TWEEZERS

Tweezers are small hand tools used for grasping objects too small to be easily handled with the human fingers. There are 4 types of tweezers : Slanted, Precision, Clamp and Curved. Each one is designated to do a different job.

Tweezer Types:

- Black anti-static coating
- Replaceable rubber tip
- Surface shiny stainless steel
- Stainless steel wafer Tweezers



JIG NUT

The tool is used to tighten outer flange lock nut when installing new blade to have the blade locked in place.



SILICON DUST CLEANER

DKleen101 is water based detergent for direct use without dilution. It is especially designed with mixed surfactants to remove semiconductor substrate particles and to clean or kill microorganisms. It is specially formulated with low foaming and disinfecting surfactants. It can be used to remove various particles from slicing or dicing substrates of silicon, silicon carbide, germanium, gallium arsenic, gallium nitride, indium phosphide.



UV LAMPS

TOSHIBA BLB UV LAMPS

The BLB (Black Light Blue) lamps use a special glass filter that absorbs almost all visible light and passes near ultraviolet energy. There are many industrial applications for these lamps such as photo exposure and chemical reactions. They can also be used for the selection of minerals by fluorescence.



SPECIFICATIONS

PRODUCT ORDER CODE	WATTS (W)	BULB SHAPE	BULB DIA (mm)	BULB LENGTH (mm)	BASE	RATED LAMP CURRENT (A)	AVE. LIFE (h)	UV ENERGY (W)	UV IRRADIANCE μCM^2	STD. PKG. Q'TY	
										INNER	OUTER
FL 4 BLB	4	T-5	15.5	134.5	G5	0.162	2,000	0.20	2.7	50	1,000
FL 6 BLB	6	T-5	15.5	210.5	G5	0.147	2,000	0.60	6.4	50	500
FL 8 BLB	8	T-5	15.5	287.0	G5	0.170	2,000	1.00	11.0	50	500
FL 10 BLB	10	T-8	25.5	330.0	G13	0.230	3,000	1.20	13.0	20	200
FL15 BLB	15	T-8	25.5	436.0	G13	0.300	4,000	2.00	21.0	20	200
FL20S BLB	20	T-10	32.5	588.7	G13	0.360	5,000	3.00	31.0	10	100
FL40S BLB	40	T-10	32.5	1,198.0	G13	0.420	5,000	7.40	66.0	10	60

USHIO METAL HILDE LAMP SERIES

Contains mercury, scandium and various other metal halogens in an inner bulb that produces a very high light output. As the high temperature of the arc discharge excites the halogenides to evaporate and separate into atoms, the metallic atoms illuminate and release the predetermined target ultraviolet wavelength

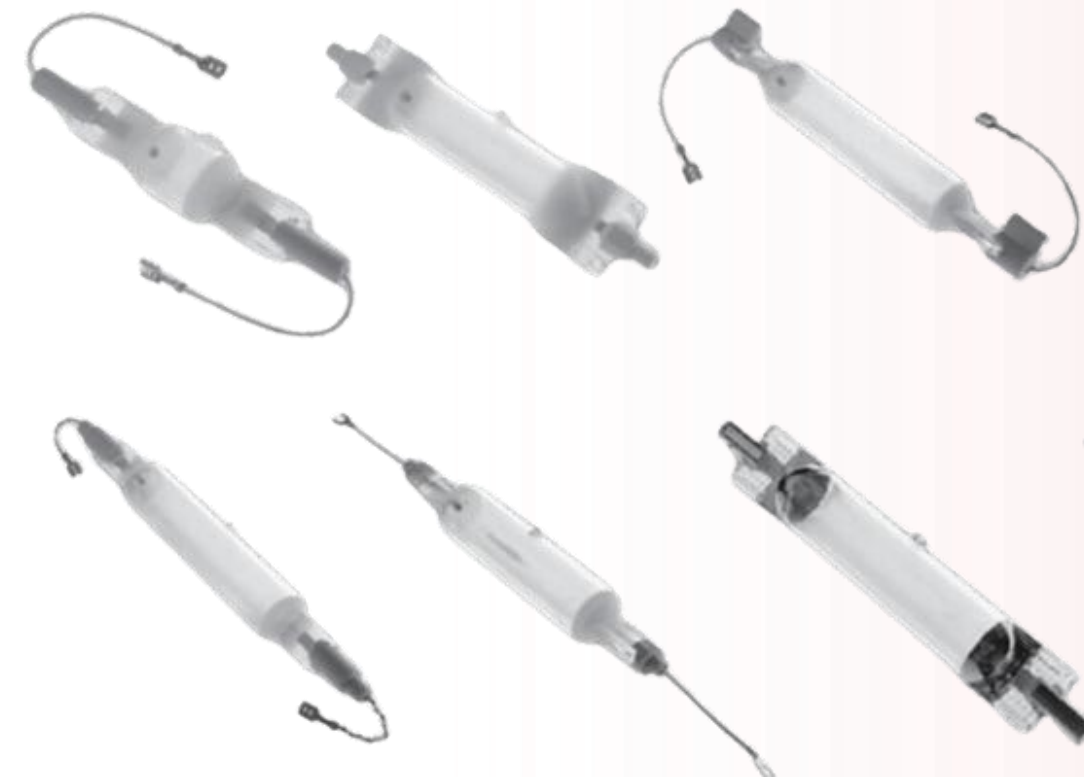

IONIZER - SUNJE

ELECTROSTATIC SOLUTIONS

ION BLOWER

It is a static electricity elimination device that can be used for short to long distance by using a fan.

FEATURES

- Medium and small size Ion Blower
- Easy maintenance via automatic tip clearing function
- Easy separable one-touch rubber cover
- Fan speed Control
- Automatic ion balance control
- LED on when ion balance/fan is abnormal
- With RMS, you can control up to 128 devices (option)



OVERHEAD ION BLOWER

It is possible to ionize whole closed space through upper installation. Due to slim and light-weight, the installation access is easier. Easy maintenance using a discharge needle cleaning brush and a detachable rubber cover.

FEATURES

- Ionizing whole closed space through upper installation
- 2 Fan (SOB-2S), 3 Fan(SOB-3S), 4 Fan(SOB-4S), 5 Fan(SOB-5S) available for customer needs
- Automatic ion balance control
- Slim size, Light-weight, Low-noise
- Easy maintenance via automatic tip cleaning function
- Fan speed control (4steps)§Interface available with Automation (PLC)
- Ion unbalance / Fan abnormal buzzer alarm
- With RMS, possible to check operation status in real time (option)



IONIZER - AP&T

ELECTROSTATIC SOLUTIONS

ION BLOWER

AP-DJ2811 intelligent control / networking type screen display ion fan using DC de static technology, high air volume fan five-speed speed regulation, stable performance, the output air volume than ordinary fans to improve 1.45 times. With LCD display, with ion self-balancing function, self-balancing range $\pm 10V$, and real-time display of the balance voltage.

FEATURES

- The safety is secured with low voltage (DC24V)
- Automatic ion balance control
Convenient tip cleaning and replacing by using sliding type of back cover
- LED alarm when ion balance has problem
- Simple tip cleaning function
- Fan speed control (2Steps)



OVERHEAD ION BLOWER

FEATURES

- Auto-cleaning when switch on;
- Default auto-cleaning time every 8 hours, Artificial emitter cleaning maintenance free;
- Five gears of stable fan speed;
- LED display shows ID address , fan speed and cleaning time;
- Duty ratio of positive and negative ion output adjustable to adjust ion balance;
- Auto balance with range $\pm 10V$.
- Light & Voice alarm when fan default and ion balance abnormal;
- Remote control ion output When Plate or material surface with high positive static charge, Press "Fan+" "IB-"; When Plate or material surface with high Negative static charge, Press "Fan-" "IB+"
- Support integrate control by PC, monitor working state of ion blower



SHOE CLEANING EQUIPMENT

SOLE CEANER

This automatic shoe soles cleaner machine is the best choice in terms of cleaning soles. So it is unnecessary to buy other soles cleaning products. Just trust us, and select our soles cleaning machines. It is competent to clean shoes made from different materials. Whether you wear heavy duty boots or other shoes, it can clean up. As a result, the machine can be used at the building entrance and other entrances with more people in and out.

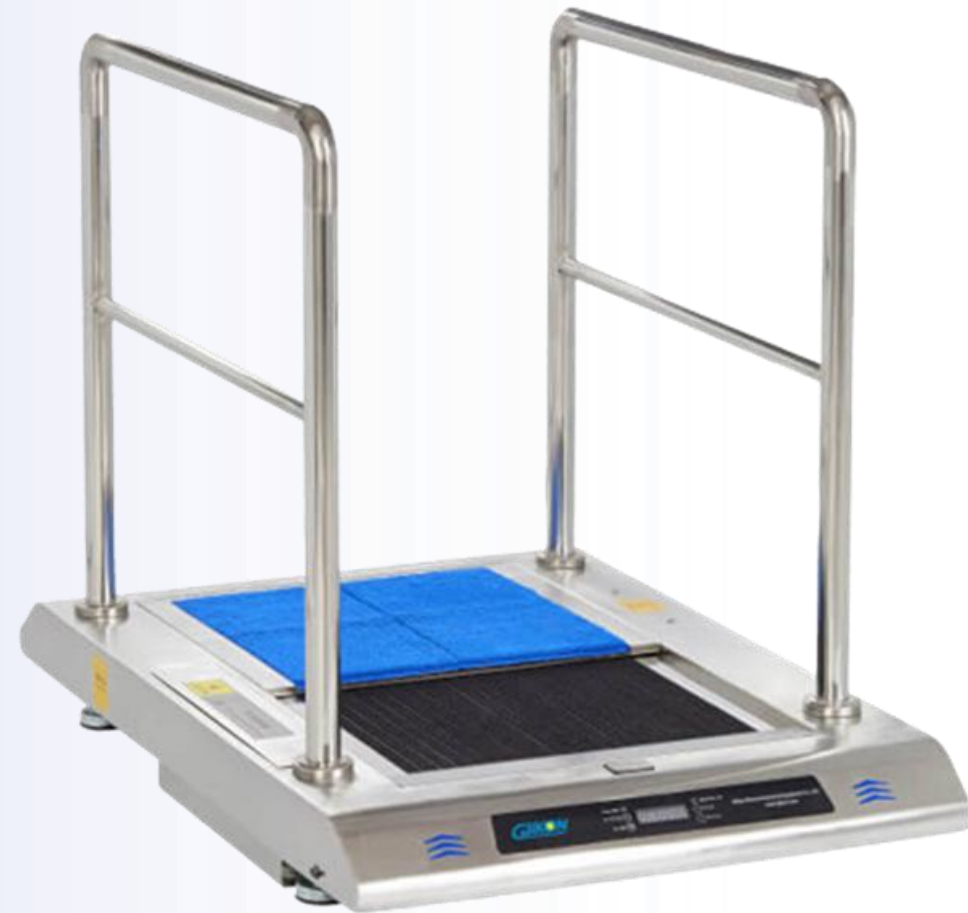

AIR SHOWER

DOUBLE DOOR CARGO

The cargo air shower refers to the air shower specially set up for the goods/materials to enter and exit the clean workshop/clean room. The cargo air shower is a non-channel floor door closer with a 90-degree positioning, so that people and goods can enter and exit.



ESD ACCESS CONTROL SYSTEM

TURNSTILE

ESD Antistatic Access Control Systems

ESD Antistatic Access Control Systems is a system that integrates a comprehensive human body electrostatic tester, an electrostatic access control device, and computerized management software to ensure that employees are prepared for electrostatic protection when entering an electrostatic protection area.

Combined with the access gate as a crowd control device, multiple entry methods (hand measurement, shoe measurement, hand and shoe measurement, and exemption) are set according to card permissions. The system provides orderly and safe passage, prevents illegal entry and exit, and quickly controls the opening of the gate in emergency situations to organize personnel evacuation.



ESD CONSUMABLES

GLOVES

We are offering different kind of gloves:

- Polyurethane Finger Coated Nylon Gloves
- Polyurethane Palm Coated Nylon Gloves
- PU Coated Finger Carbon Fiber ESD Gloves
- PU Coated Palm Carbon Fiber ESD Gloves
- PU Coated Finger Copper Fiber ESD Gloves
- PU Coated Palm Copper Fiber ESD Gloves
- Latex Gloves
- Nitrile Gloves
- PVC Gloves
- ESD Embossed Gloves
- Lint Free Gloves



ANTI-STATIC WRIST STRAP

Specifications:

- Ground Resistance: $10^6 \Omega$
- Static Electricity Discharge Time: $<0.1 \text{ s}$



ALCOHOL DISPENSER BOTTLE

Specifications:

- Material: Anti-static material combined with HDPE
- Color: Blue, Pink, Yellow, Green
- Volume: 100ml, 150ml, 200ml, 250ml, 500ml



ESD CONSUMABLES

ESD RUBBER MAT

Color	Blue, Green, Gray, Black			
Thickness	2mm, 3mm			
Ant-static surface	Surface Resistance	$10^6-10^9\Omega$	Specification	Product Item
	Abrasive Static Potential	$\leq 100V$		
Conductive surface	Surface Resistance	$10^4-10^6\Omega$	0.6x10m 1.0x10m 1.2x10m	JETM-610 JETM-110 JETM-1210
	Abrasive Static Potential	$\leq 50V$		
Volume Resistivity		$10^6-10^9\Omega$		

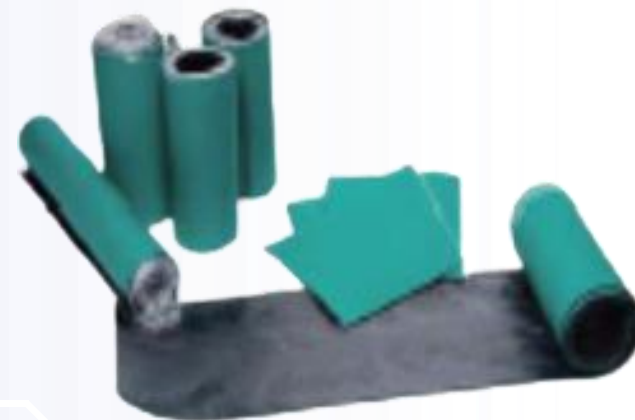

STICKY MAT

Specifications:

- Material: PS Board + Non slip net
- Size: 19"x37", 19"x46", 25"x37", 27"x46"
- PS Board Color: White
- Non Slip net color: White, Grey, Red, Blue

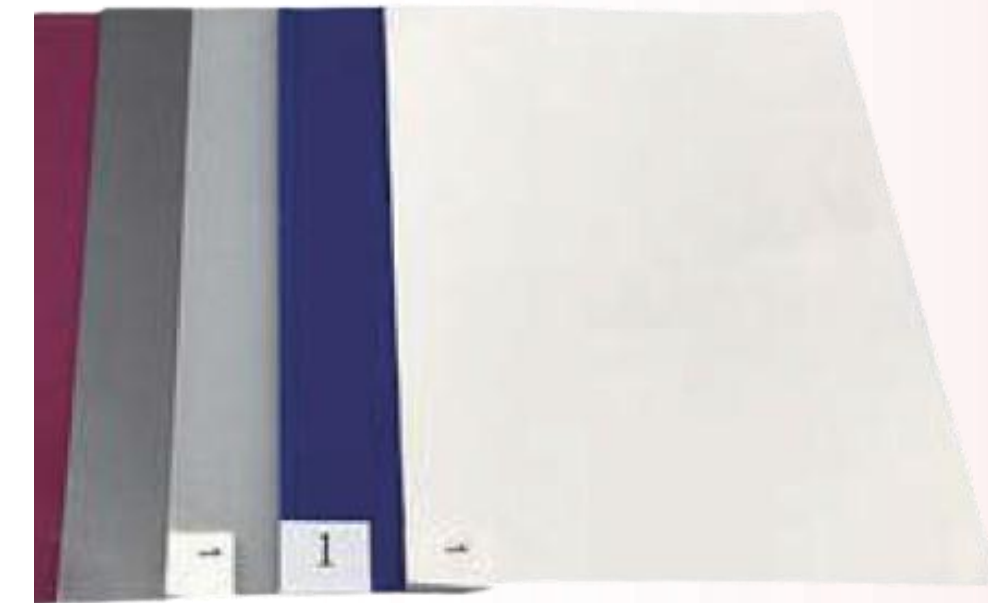

ESD CONSUMABLES

NON-WOVEN FACE MASK

Specifications:

Description: Non-woven face mask is made eco-friendly non-woven fabrics with breathable, non-toxic, flexible, durable and dissolve functions.

Style: Earloop, Tie-on

Ply: 1ply, 2ply, 3ply

Size: 17.5cm x 9.5 cm

Color: White, Blue

Packing: 50pcs/bag, 50pcs/box



ACTIVATED CARBON FACE MASK

Specifications:

Description: Non-woven face mask is made eco-friendly non-woven fabrics with breathable, non-toxic, flexible, durable and dissolve functions.

Style: Earloop, Tie-on

Material: Upper cloth+ Activated Carbon + Filter Paper + Inner Cloth

Size: 17.5cm x 9.5 cm

Packing: 50pcs/bag, 50pcs/box



CLEANROOM WIPER

Features:

Excellent cleaning effect.

Efficiently fast absorption water and oil.

Use laser sealed edges, low dust.

Soft, no scratches on the surface of wiped products.



Material	100 % Polyester
Edge Sealed Way	Laser Sealed, Thermal Sealed, Cold Sealed, Ultrasonically Sealed
Color	White
Size	4"x4", 6"x6", 9"x9", 12"x12"
Weight	110g/m ² , 120g/m ² , 125g/m ² , 130g/m ² , 140g/m ² , 145g/m ² , 160g/m ² , 175g/m ²
Clean Class	10, 100, 1000, 10000, 100000
Packing	4"x4": 600pcs/bag, 10bag/carton 6"x6": 150pcs/bag, 20 bags/carton 9"x9": 150pcs/bag, 10bags/carton 12"x12": 50pcs/bag, 10bags/carton

ESD CONSUMABLES

CLEANROOM SWAB

Features:

- Cloth/Foam Tip
- Special sealing edge technology on convergent of sponge/cloth tip
- High absorption, saturately, low particles
- PP or antistatic plastic handle
- High cleanliness, low dust



SMT AUTOMATIC STENCIL WIPER ROLL

Features:

- Ground Resistance: $10^6 \Omega$
- Static Electricity Discharge Time: $<0.1 \text{ s}$

Application:

- Suitable for cleaning ink, SMT printing machines.
- Industrial Cleaning: SMT production line, Semiconductor assembling line, Optical & PCB products



Machine Model	Wiper Roll (mm x m)	Inner Core (mm)
KME	480 X 30	38 x 480
KME	545 X 15	19.5 x 545
PANASONIC	270 X 10	38 x 280
PANASONIC	360 X 10	38 x 360
FUJI	400 X 11	25 x 400
FUJI	500 X 11	25 x 500
PANA	360 X 12	38 x 360
PANA	410 X 36	38 x 410
SAMSUNG	400 X 7	20 x 460

MICROSCOPES

INSPECTION SOLUTIONS

SMZ-0745B Stereo Microscope

In a wide field of vision, a flat picture plane and a positive image with superb contrast are generated. The picture quality is brighter and clearer, the binocular visibility is changeable, and the best vision height is found in the periphery field of view.

It may be used in a variety of sectors, including jewelry appearance inspection, phone maintenance, and SMT product appearance inspection. The three-eye model may be integrated into the marketplace, offer real-time imaging on the display, and increase the capabilities of image analysis, image measurement, and other operations.

FEATURES

- Standard optical imaging system
- Standard configuration of production line, suitable for batch appearance inspection.
- Binocular & Trinocular Digital transmission are optional
- Continuous zoom objective lens 0.7x ~ 4.5x (6:3:1)

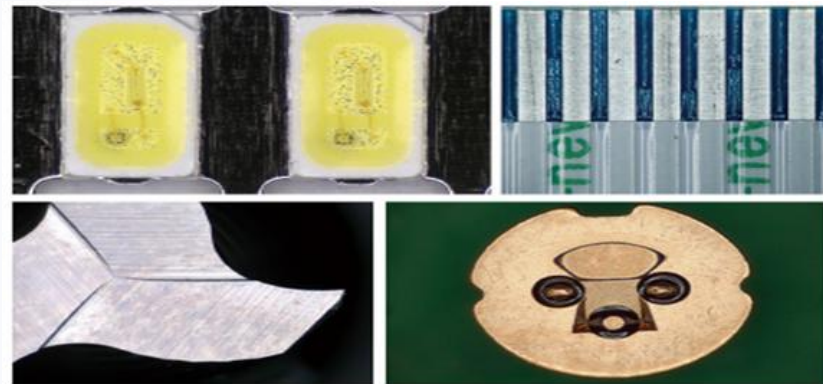

BA Series Metallurgical Microscope

It is suitable for semiconductor testing, FPD, packaging, circuit substrate, casting, metal materials, precision molds and other fields. It provides observation functions such as dark field, polarization and differential interface (DIC) to calmly meet the observation needs such as quality management and manufacturing process inspection.

FEATURES

- Infinite optical objective system
- 100x objective WD 3mm
- Optional H-type, Z-axis marking and measurement
- Complete polarizing system, micron level analytical imaging
- Support High pixel HDM or PC interface industrial camera
- Optional 4" & 6" centers support customization of long-distance movement stage

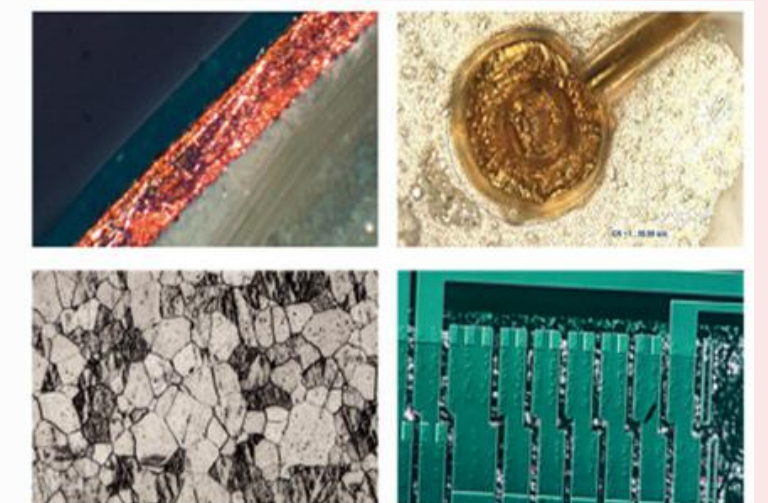

MICROSCOPES

INSPECTION SOLUTIONS

Microscope CCD Camera

Introducing our versatile solution, which is ideal for all of your semiconductor applications. This product provides a variety of observation functions. With a built-in 15" monitor to decrease eye strain, this wonderful tool is designed to easily give visual inspection.

FEATURES

Image Sensor : 2 MP Sony Sensor or 16 MP
Panasonic Sensor

Drawtube : Monocular

Zoom : 0.7x – 4.5x

IR Remote : 5 meter max

HDMI Resolution: 1080P60

Image Resolution:

For 2 MP : 1920x1080(16:9)

1440x1080(4:3)

For 16 MP : 4608x2592(16:9)

4608x3456(4:3)

Video Resolution: 4KP25

1080P60

720p120

Pixel size : 3.75um x 3.75 um

1.34 um X 1.34 um



Compact Microscope CCD Camera

Introducing our versatile solution, which is ideal for all of your semiconductor applications. This product provides a variety of observation functions. With a built-in 8.0" monitor to decrease eye strain, this wonderful tool is designed to easily give visual inspection.

FEATURES

- Screen size: 8.0 Inch IPS,
- Screen resolution: 1280x800
- Image sensor: 1/3-inch Sony 13MP,
- Pixel size: 1.12um x 1.12um
- Image resolution: 4800x2700、7680x4320 (Interpolation 33M)
- Video resolution: 3840x2160P30(Clear)、10800P60(Smooth);
- HDMI resolution: 1080P60
- USB resolution: 3840x2160P30 (H264) 、1080P30、720P60
- Zoom rate: 10X~430X (Optical 5X~33X, Digital 1X~16X)
- Support LCD+HDMI+USB(UVC) output display
- Rotating lens barrel design, precise focusing and smooth feeling
- Touch type white LED design, simple operation and intuitive viewing
- Support local mouse operation + measurement function
- (Point, Line, Circle, Angle)
- Support full screen freezing, left and right, up and down, 1/4 PIP comparison
- Support 8 groups of grids, and position, color, thickness are adjustable.



MICROSCOPES

INSPECTION SOLUTIONS

3D Microscope EC-H380

1080P High Definition(HD) Digital Microscope and measuring video electronic digital microscope. 2MP HD image resolution, can measure, take photo and take video. It is microscope with the most competitive price, widely used in observation of surface defects.

SPECIFICATIONS:

3D Observation Manual
Magnification 24x - 160x
Resolution 1920*1080P@ 60FPS
Pixel 2.0MP
Digital Transmission HDMI
Working Distance 70mm

Functions:

Take Photo
Take Video
2D Measurement
3D observation
4 Side Lighting mode(dimming)
Mouse Control
USB disk saving data
2D Measurement: Points, lines, circles, distances, angles, radians, areas, diameters, radii, perimeters, etc.
3D Measurement: Not applicable



3D Profiling Microscope

1080P High Definition(HD) Digital Microscope and measuring video electronic digital microscope. 2MP HD image resolution, can measure, take photo and take video. It is a microscope that is capable of measuring different shapes with depth measurements.

SPECIFICATIONS:

Magnification: 24x-154x
Resolution: 1920*1080 @60/FPS
Pixel: 2 MP
Digital Magnification: 40*480x
Digital Transmission: USB (Connect to PC only)
Lighting: LED Lamp
Column: $\pm 90^\circ$ tilt
Z-axis: Motorized
X-Y- axis: Manual or Motorized (optional)
Movement Svstage: Size of Stage: 125*180mm; X-Y movement: 60*60mm

Functions:

Take Photo (with stitching)
Take Video
3D profiling
2D Measurement: Points, lines, circles, distances, angles, radians, areas, diameters, radii, perimeters, etc.
3D Measurement: height, depth, radian, irregular groove height, etc.

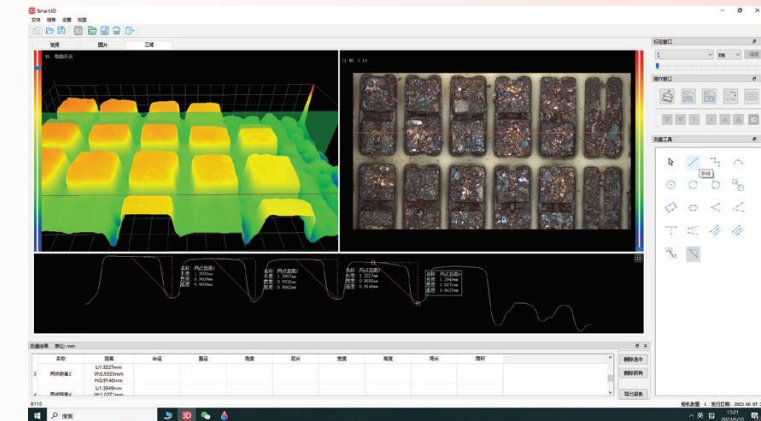

MONITORING SOLUTIONS

MINI CAMERA

A compact 2.0 MP camera with a 3.7mm pinhole lens, offering HD 1080P resolution, real-time video at up to 30fps, and low light performance (0.1Lux). It features H.264 compression, JPEG capture, and an IR-CUT filter for day/night monitoring. Its small size (34x34mm) is perfect for small mounting area.

SPECIFICATIONS

Camera

Effective Pixels: 2.0 MegaPixels
Main stream:1920*1080@25fps
Sub stream:640*360@25fps
Image Sensor: 1/2.9" SC2053 CMOS Sensor
Adjust Parameters: DWDR, BLC, DNR, AE, AGC, D&N, Mirror ,Flip, etc.

Video

Compression: H.264 Main profile
Stream: Support dual stream, AVI format
Bit Rate: Support 0.1M ~8Mbps bit rate adjustable
Frame Rates: Support 1~30fps adjustable

Recording: Does not support loop recording, monitored via app or browser.

Network

WEB Browser: Support WEB remote config (IE, Safari, Google Chrome, Firefox etc.)
Smart Phone: Mobile Remote Monitoring (iPhone or Android using direct hotspot or Wi-Fi connectivity)

General

Storage: SD Card (included) 128GB
I/O Connector: 1*DC Connector ,1* RJ45(10/100M Network)
Supplied Voltage: DC12V
Power Consumption: IR On: 600mA max., IR Off: Less than 200mA
Working Environment: -10°C~+60°C, 10%~90% (Built in Heater being optional added for environment lower than -20°)
Weight: 0.3kg

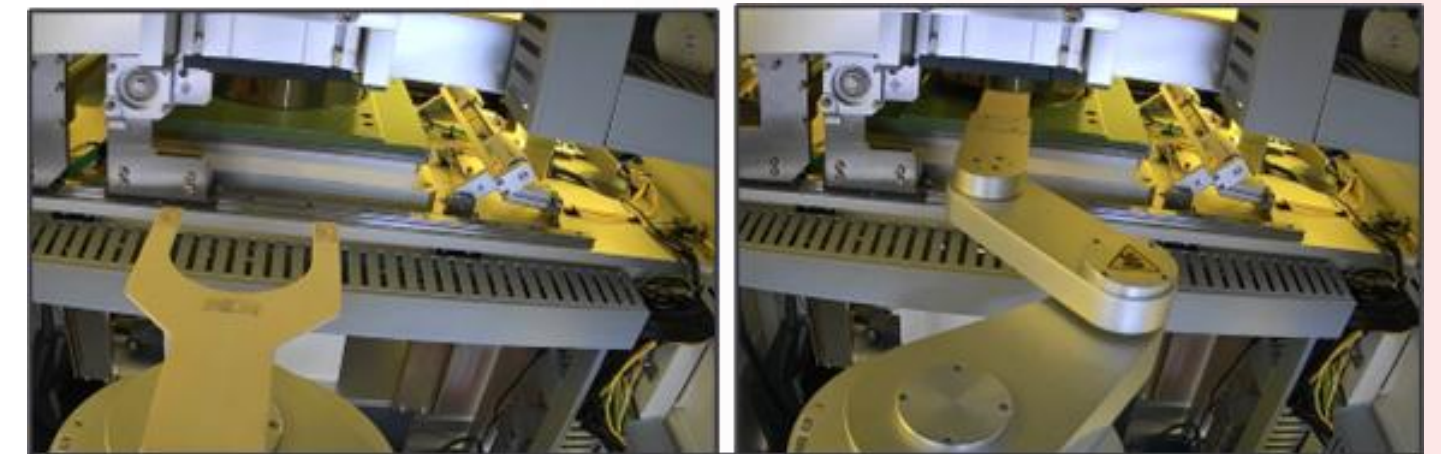

Sample photo taken from video

VACUUM WAND

for WAFER HANDLING

C SERIES

The body of the vacuum tweezers uses nylon resin containing carbon fiber (Torayca), which has excellent physical properties and conductivity. In addition, the internal valve part uses fluororesin, and the structure is such that the surroundings are covered with carbon fiber-filled nylon through a special molding method that does not impair airtightness.

The nylon connector connected to the rear of the main unit is controlled by a specific resistance value of 10 to the 6th power \pm 2 power. The adsorption tip uses conductive PEEK resin containing carbon fiber, which has excellent chemical and heat resistance, and maintains stable performance even when used for a long period of time.

Abundant sizes of adsorption chips are available, and a wide range of selections are available for each wafer size.



Code No.	Description	Material	Corresponding axis		Cap		Size (mm)			
			100	106	161	260	T	IN	L1	L2
90	Conductive Y tip 5-6 in	Conductivity PEEK			●		2.7	16	26	82
91	Conductive Y tip 8 in				●		3	26	33	89
92	Conductive Y tip 5 in				●		3	32	39	95
95	Conductive Y tip 6 in			●		●	2.7	15	27	37
96	Conductive Y tip 8 in			●		●	3	27	32	43
97	Conductive Y tip 1 in			●		●	3.7	31	37	43
98	Conductive Y tip 12 in				●		3.5	31	39	129
99	Conductive Y tip				●		3.5	48	58	151

X-Ray Inspection

AX9500

160kV Open Tube 3D CT X-Ray

FEATURES

- 160kV open Tube X-ray source
- High Resolution Navigation System
- High Resolution FPD Detector
- Multi-angle image tracking system
- 6-axis linkage, 360° arbitrary viewing angle detection
- 3D tomographic dual CT scanning system (Planar CT+cone beam CT) can perform numerical control programming detection, high detection accuracy and repeatability



AX8300Si

Semicon In-line X-Ray

FEATURES

- 2 μ m closed tube, high resolution
- UPH>50K, high detection efficiency
- NG marking for automatic sorting
- LeadFrame&WireBonding automatic detection
- The box material is up and down as a whole, easy to operate
- SPC real-time data statistics



Innovative Solutions, Excellence in Service

RF PLASMA CLEANING SYSTEM

BATCH TYPE

Plasma was used before MD to improve the delamination between epoxy resin and substrate.

FEATURES

- The 1.13.56 mhz power supply features a short cleaning time, no sputtering, and low power consumption, temperature ;
- Implement the simultaneous cleaning of eight material boxes.
- Software-independent design and simple operation, according to the actual manual operation habit optimization
- Modular design, imported configuration, stable operation, and simplicity.



IN-LINE VARIABLE RAIL

Plasma was used before MD to improve the delamination between epoxy resin and substrate.

FEATURES

- Wide versatility: patented stepless rail adjustment. The technology is suitable for different widths of products (25~100mm).
- Easy to operate: one-click rail adjusts automatically switching products, software intelligence.
- Stable and efficient: four-track dual platform cycle. The operation is stable, efficient, and reliable.
- High performance: patented cavity design ensures high-quality and long-term cleaning results.
- Easy maintenance: PE cleaning mode will not damage the product, the cavity is not easy to clean, and it can be wiped clean with alcohol.



Innovative Solutions, Excellence in Service

IC LASER MARKING SYSTEM FOR EMC & L/F

The IC laser marking system is designed for Epoxy Molding Compound (EMC) & Lead Frame (L/F) surface marking (including letter, number, logo, symbol & QR code).

APPLICATION

- The IC package types applicable to this marking system are SOP/SOT/SSOT/QFN/DFN/BGA and Substrate.
- This system has the characteristics of large marking range, strong compatibility, high marking accuracy, fast speed and good stability.
- The software is easy to operate, displays fault location, alarm indication with corresponding solutions and other prompt functions.
- The system consists of loading and unloading module; Conveyor with strip levelling module; Pre-mark and post-mark visual inspection (Optional); Laser module; Dual CCD visual positioning module (Optional); dust extraction module; ion fan etc.
- Compatible with various IC lead frames of different lengths and widths.

SPECIFICATION

- Laser marking accuracy $\pm 0.05\text{mm}$.
- Laser line width $0.03\sim 0.04\text{mm}$.
- Minimal character size 0.15mm .
- Marking depth $0.01\sim 0.025\text{mm}$ (depends on material).
- Compatible strip lengths $160\sim 300\text{mm}$; widths $50\sim 100\text{mm}$.
- Warpage capability max 4mm (depends on strip thickness & hardness).
- Static residual value $< 50\text{V}$.
- Power consumption
- Laser equipment: $220\text{V}/50\text{Hz}$; 40A ; 5kW .
- Dust collector: Three-phase $380\text{V}/50\text{Hz}$; 32A ; 3kW .

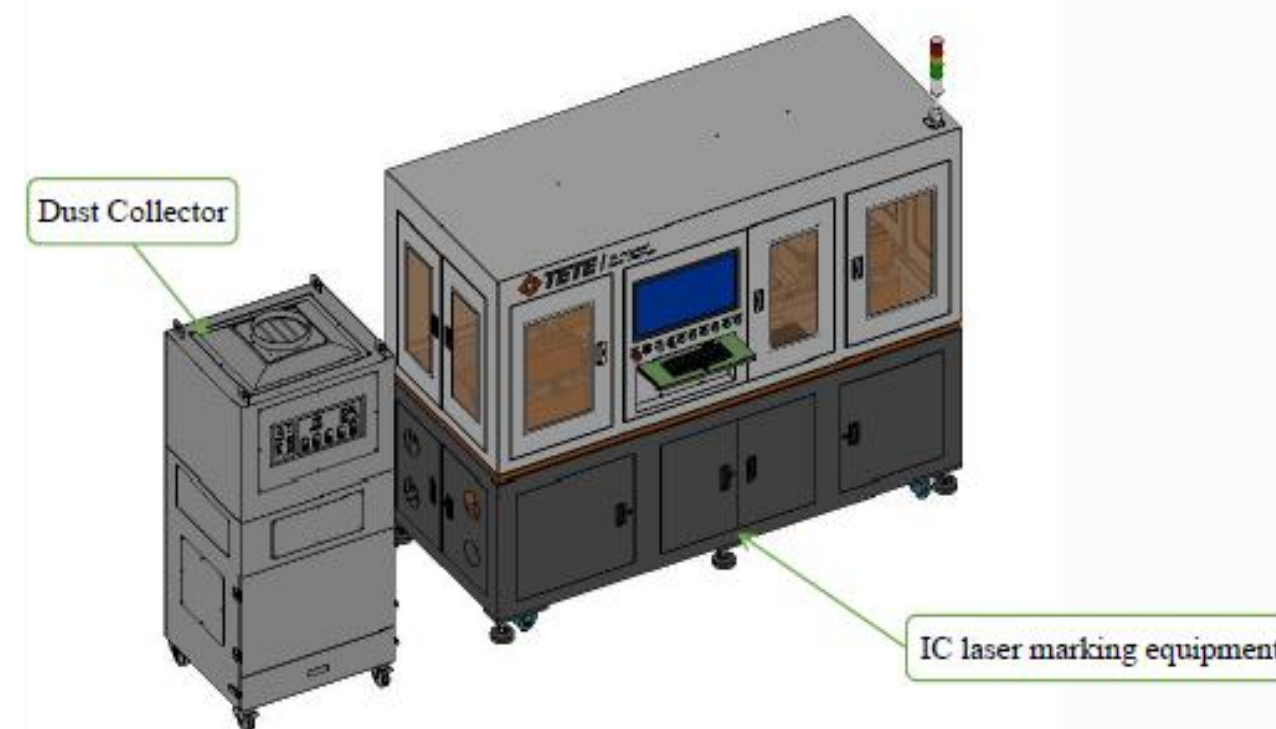

Multi Slot Magazine for EMC

IC AUTOMATIC LASER MARKING EQUIPMENT

SPECIFICATION

- Marking area format 200mmx300mm
- The fastest marking speed: 1000mm/s
- Minimum line width: 0.06mm
- Minimum character size: 0.5mm
- Highest resolution: 0.0025mm
- Positioning accuracy: +/-0.05mm
- Importable file formats: Importable vector files (*.dxf*.wmf*.plt) Bitmap file (*.bmp)
- Compatible strip length: 180-300mm
- Compatible strip width: 50-100mm
- Allow arch bending of material strip: <2mm

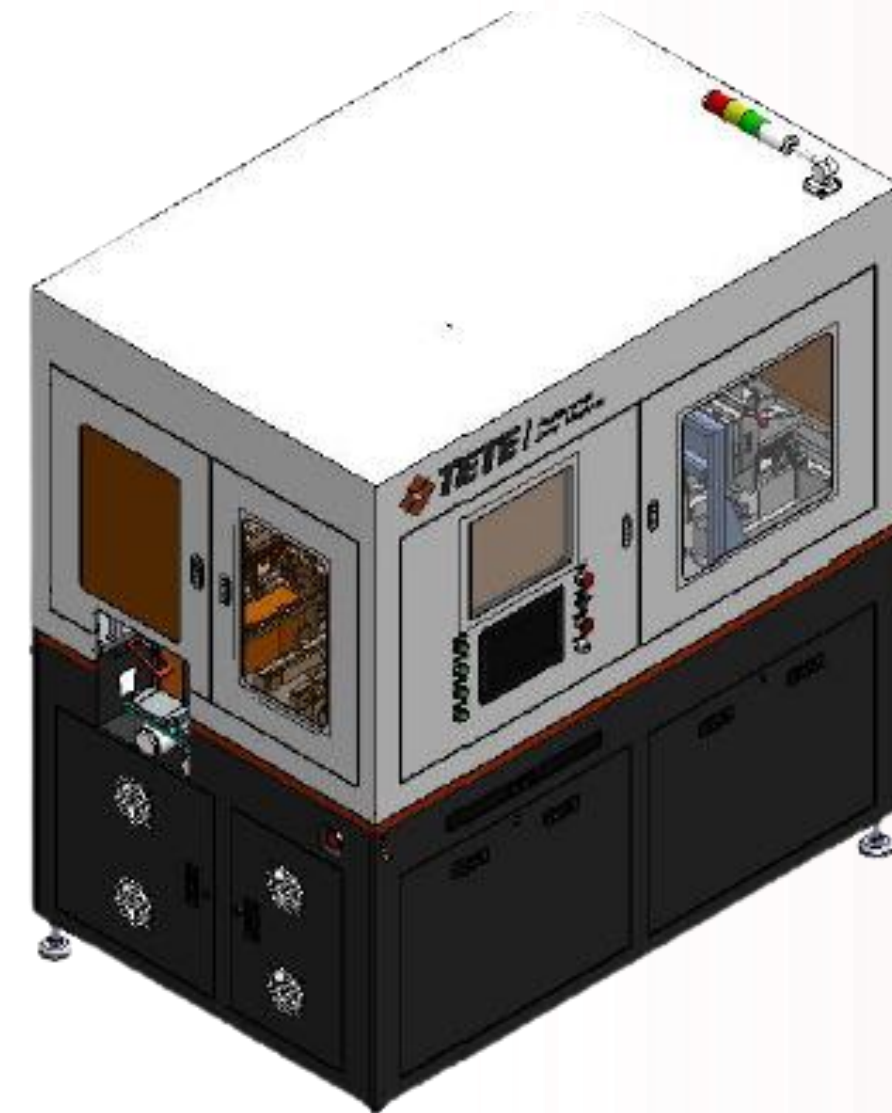
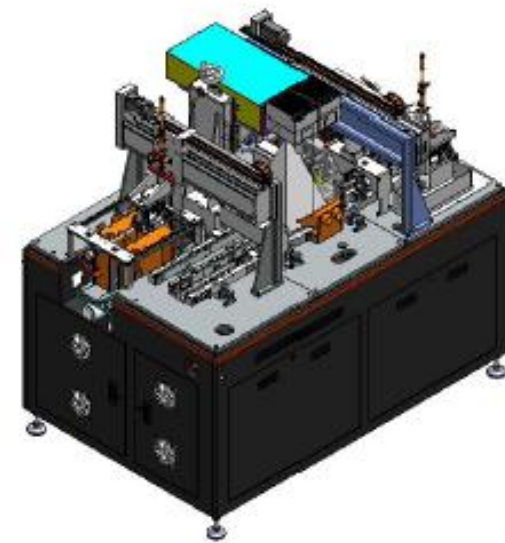
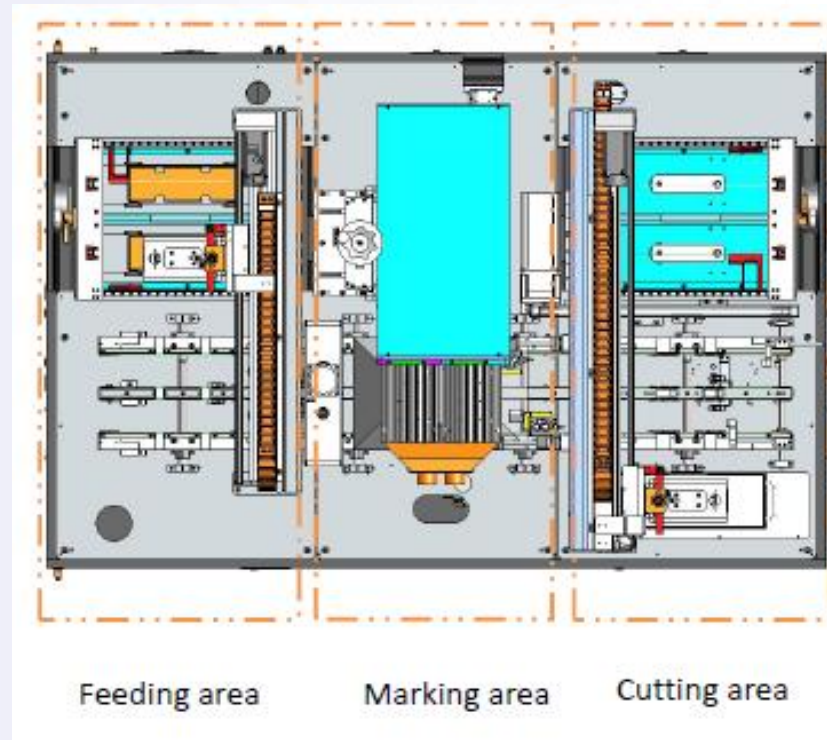

ULTRASONIC CLEANING MACHINE

CT SERIES

Open/Fully Enclosed batch handling type Cleaning System which consists of multiple tanks, capable of providing high throughput and performing high flexibility processes.

FULLY AUTOMATED

Fully automated cleaning system with high process flexibility & precision recipe control system, where all process sequences for each cleaning requirement can be adjustable by the user.

PROCESS BASKET/BARREL

Process basket & barrel options cater for different parts handling, where barrel is capable of rotation movement.

HIGH FLEXIBILITY

CT-Series is being designed with a solid modular platform that could cater to multiple chemistries, varies precision cleaning & drying technology in a single system.

ROBOTIC ARM

JKS SmartBOT handling features precision positioning & speed control system with process synchronized capability. It is also designed to minimize risk of particle generation during movement (cleanroom compliance).



DI WATER RESISTIVITY CONTROLLER UNIT

CO2 INJECTOR/BUBBLER

It is designed to avoid contamination of wafers and to control resistivity of DI water.

PANEL MOUNT

The P series can be installed on a rack in accordance with EIA (Electronics Industries Association) standard.

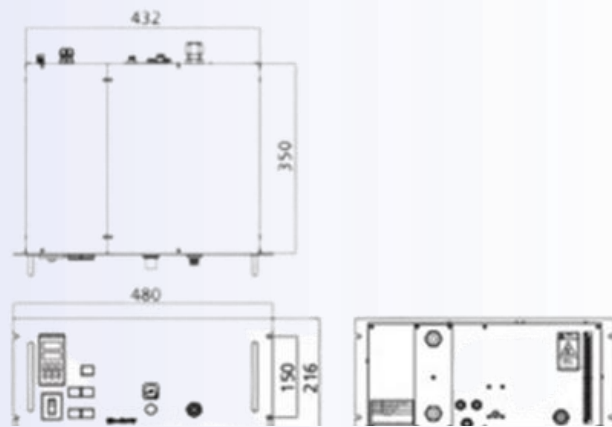

CABINET TYPE

The C series has a cabinet with a capacity of two CO2 cylinders

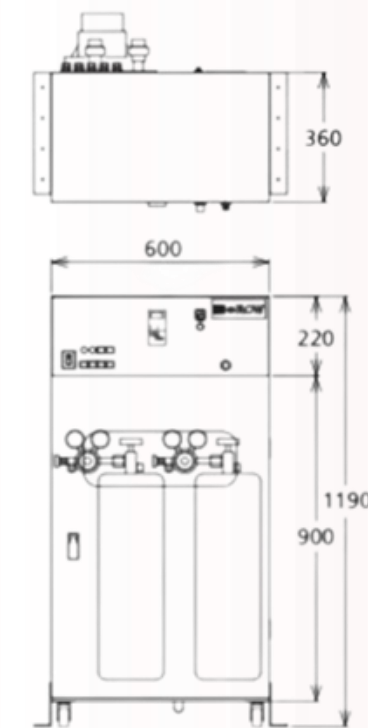

VOLTAGE SAG PROTECTOR

TSP SERIES

TSP is ONE-STOP solution where instant black out compensation and surveillance monitoring function are integrated.

FEATURES

- Super highspeed switching within 2 ms without instant voltage drop
- Integrating wattmeter: Compute the integrated watt-hour meter in respect of amount of electricity consumption
- Low power consumption at stand by mode with off line compensation
- Low cost
- High Efficiency / eco friendly



CENTRIFUGAL MIXER

PLANETARY MIXER

A special kind of mixer, the planetary centrifugal mixer simultaneously removes air bubbles and evenly distributes/mixes the components. The materials-filled container is controlled by a central force produced by rapid revolution and rotation along the orbital path.

FEATURES

- Single/Double Cups
- Multistep Parameter
- Optional Vacuum
- Various Adapters, customizable
- Wide range scale of revolution and rotation.



Ultra Low Temperature Freezer

Ultra Low Temperature Freezer

Product Feature		
Temperature Control	Microcomputer digital control. Temperature realization display. Display accuracy is 0.1°C	
	The temperature can be adjusted from -15 to -40 degrees.	
	Alarm Temperature can be set.	
Security System	With a perfect alarm system. Showing with sound and light .	
	Protection	Password protection, frequent start-up protection, etc.
	Alarm types	High and low temperature alarm, sensor failure alarm
Refrigeration System	The SECOP compressor make the performance stable.	
	The condensing fan brand in EBM, which made the noise in low.	
	Ultra-thick foam layer, double sealing of the door body, effective protection of the temperature inside the freezer.	
	100% CFC free.	
Ergonomic Design	Easy Access	Built-in 304 stainless steel shelves can be adjusted.
	High Security	The door is equipped with a security lock.
	High Applicability	187V-242V wide voltage design, suitable for unstable voltage environment.
Certifications	CE, FDA,ISO9001,ISO13485	
Power Supply	220V AC / 50Hz	



Other Services Offered

M7 Technology Solutions, Inc. offers other services aside from the product line-up mentioned.

Other services offered are:

- a. Chuck Table Refurbishment
- b. Spindle Refurbishment
- c. Spare Parts Sourcing (PC unit, boards, OEM parts, etc.)
- d. Automation and Integration
- e. Air-conditioning and Chiller Installation (Healthcare)



Innovative Solutions, Excellence in Service



+63 (2) 8294 3316 (Metro Manila)
+63 (32) 234 5748 (Cebu)



semicon@m7group.com.ph



www.m7group.com.ph



Block 4C Lot 35 Silver Street Sapphire Hills
Victoria Homes Subdivision Tunasan
Muntinlupa City 1773 Philippines

Marangal, Makatao, Matapat, Matatag, Maparaan, Mahusay, Mapagkakatiwalaan